

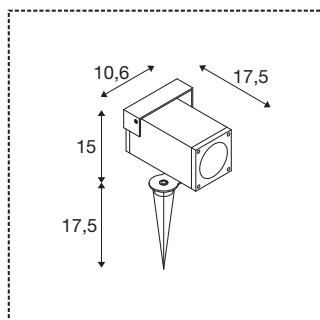

## THEO BRACKET SP QPAR51

### outdoor ground spike light anthracite

THEO BRACKET makes the extensive range of options offered by the popular SLV THEO light family even more versatile: this earth spike light is perfect for creating accent lighting in outdoor areas. It also offers the option of using different lightbulbs, such as smart GU10 bulbs - which are perfect for intelligent control and adjusting lighting characteristics depending on the context.



### TECHNICAL DATA

Item no.:	1004652
Socket	GU10
Lamp	LED GU10 51mm
Number of sockets	1
Lamps included	No
Primary nominal voltage	220-240V ~50/60Hz mA/V
Tilt range	70 °
Length	17.5 cm
Length of earth spike	17.2 cm
Width	10.6 cm
Height	15 cm
Net weight	1.093 kg
Gross weight	1.375 kg
IP Code	IP 44 / IP 65
Safety class	I
Assembly	Surface
Assembly details	Ground
Wattage	7 W
Color	anthracite
BIG WHITE Page	601

## Recommended lamp

1004972	LED QPAR51 , lightbulb GU10 2700K 36°
1004973	LED QPAR51 , lightbulb GU10 300K 36°
1004974	LED QPAR51 , lightbulb GU10 4000K 36°
560122	MASTER LED GU10 , Philips, 3.5W, 40° , 2700K, dimmable